

BLOCK P.L.M. N°3.

Modèle 1899

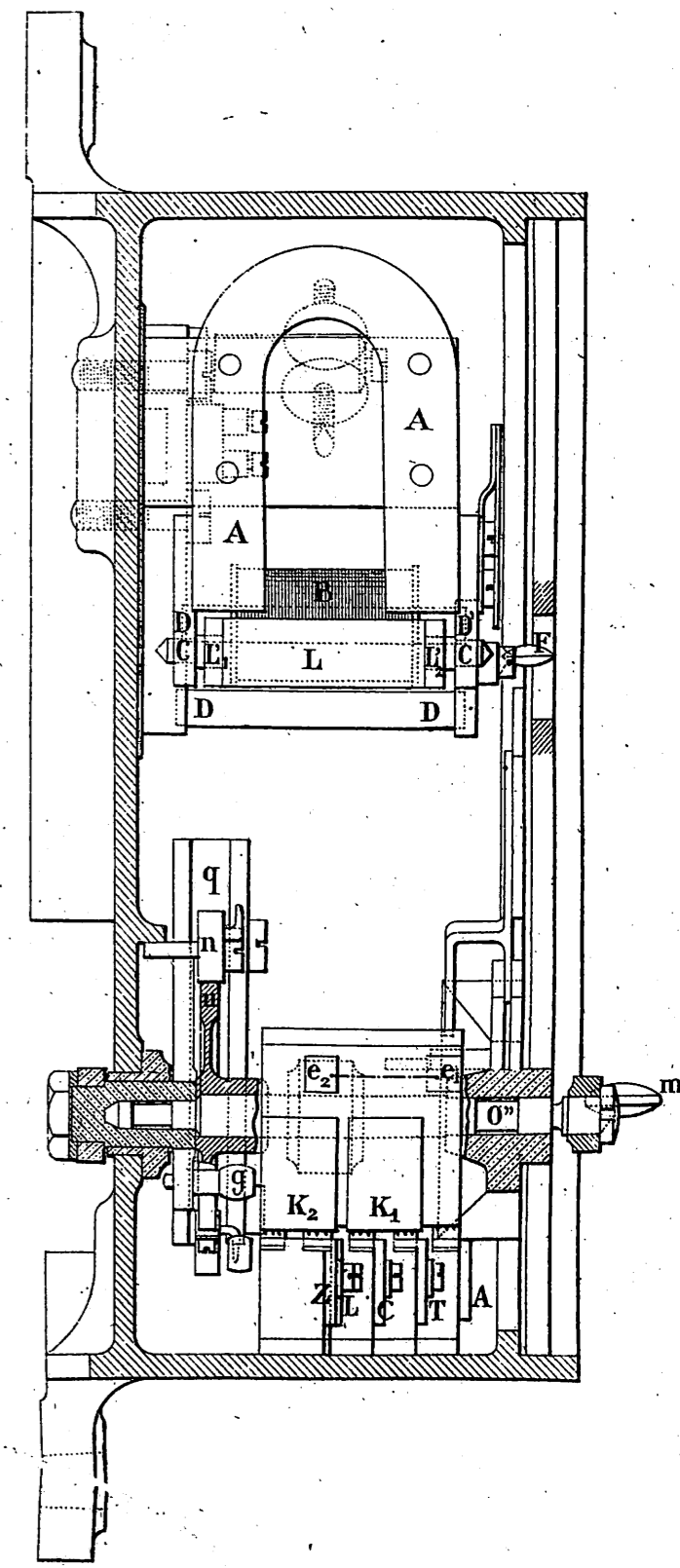
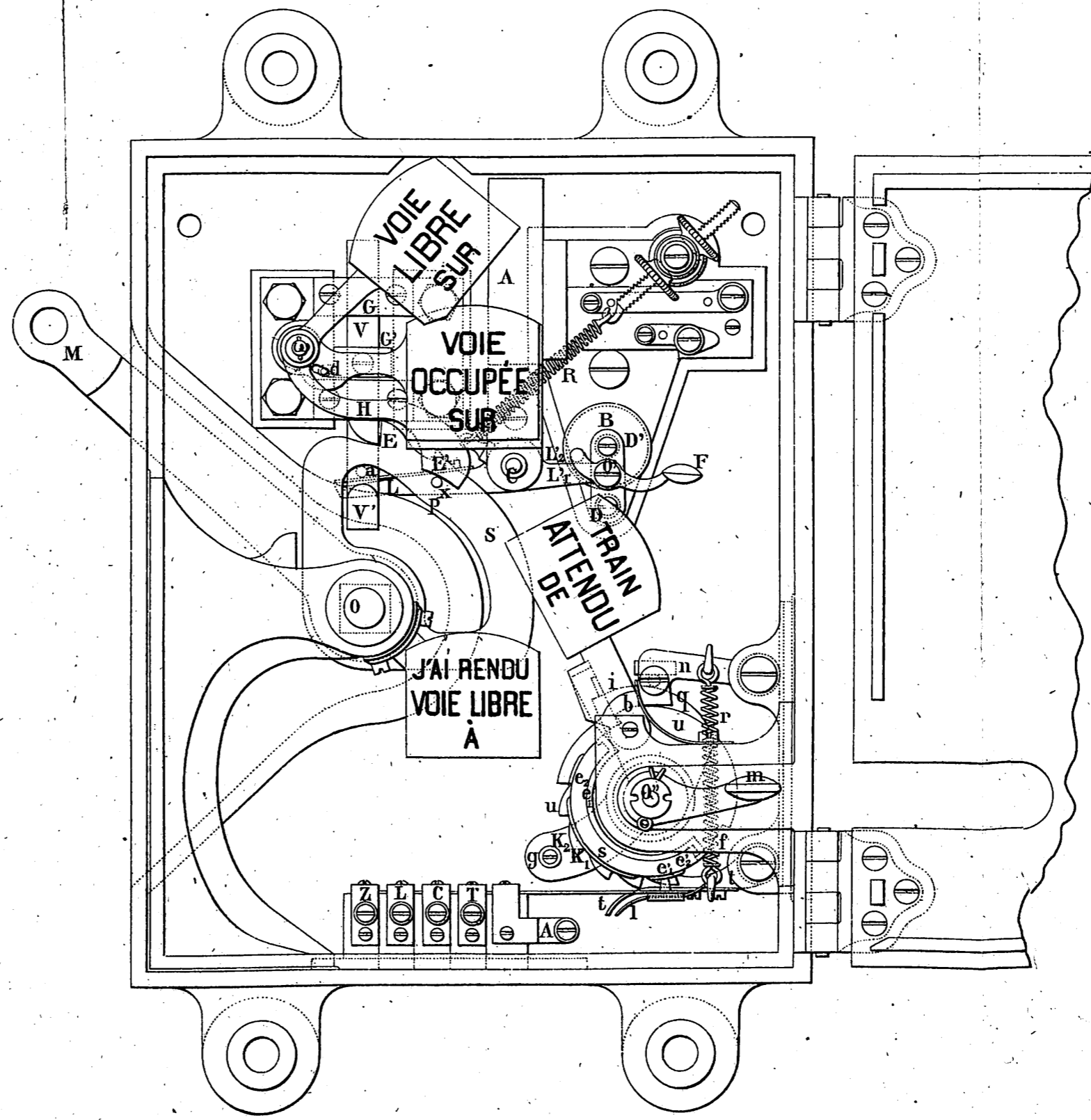
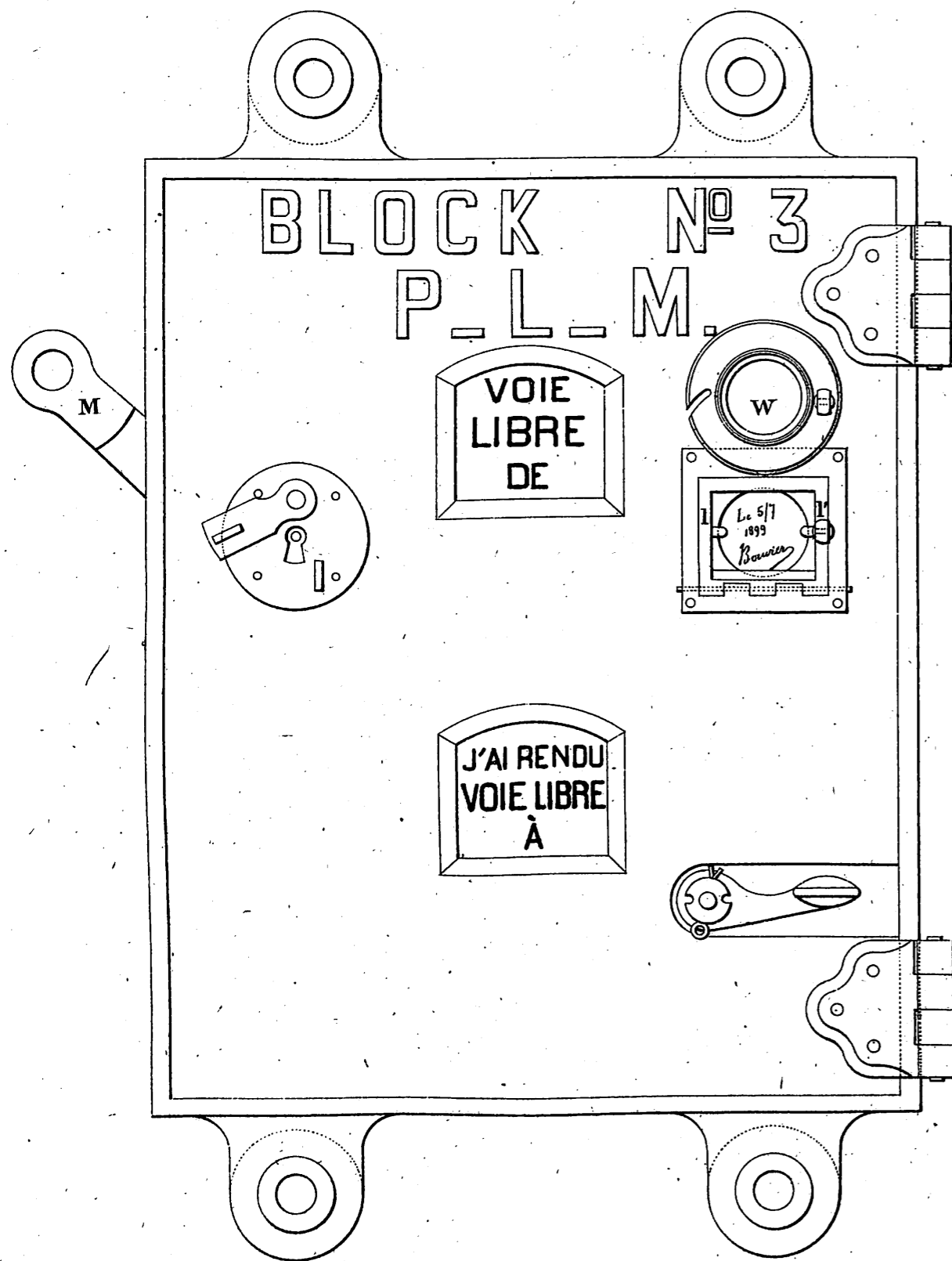

sc pour block N°3
ne sur socle avec bouton poussoir.

Fig. 1.

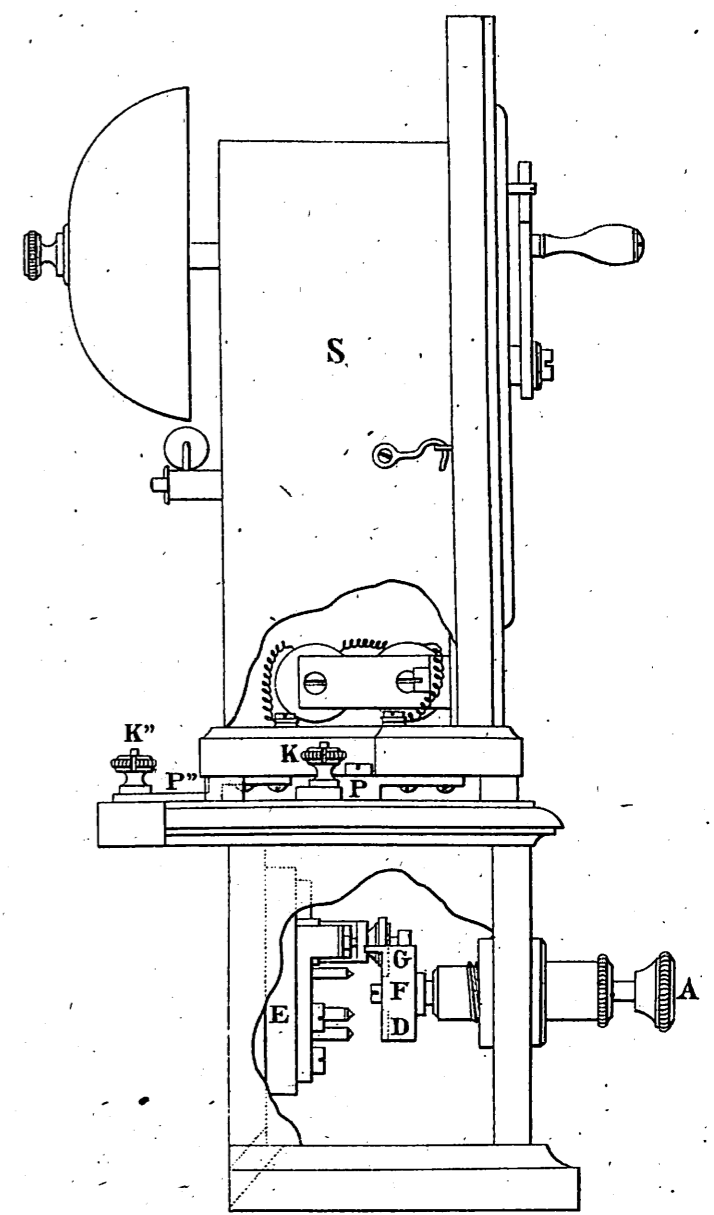
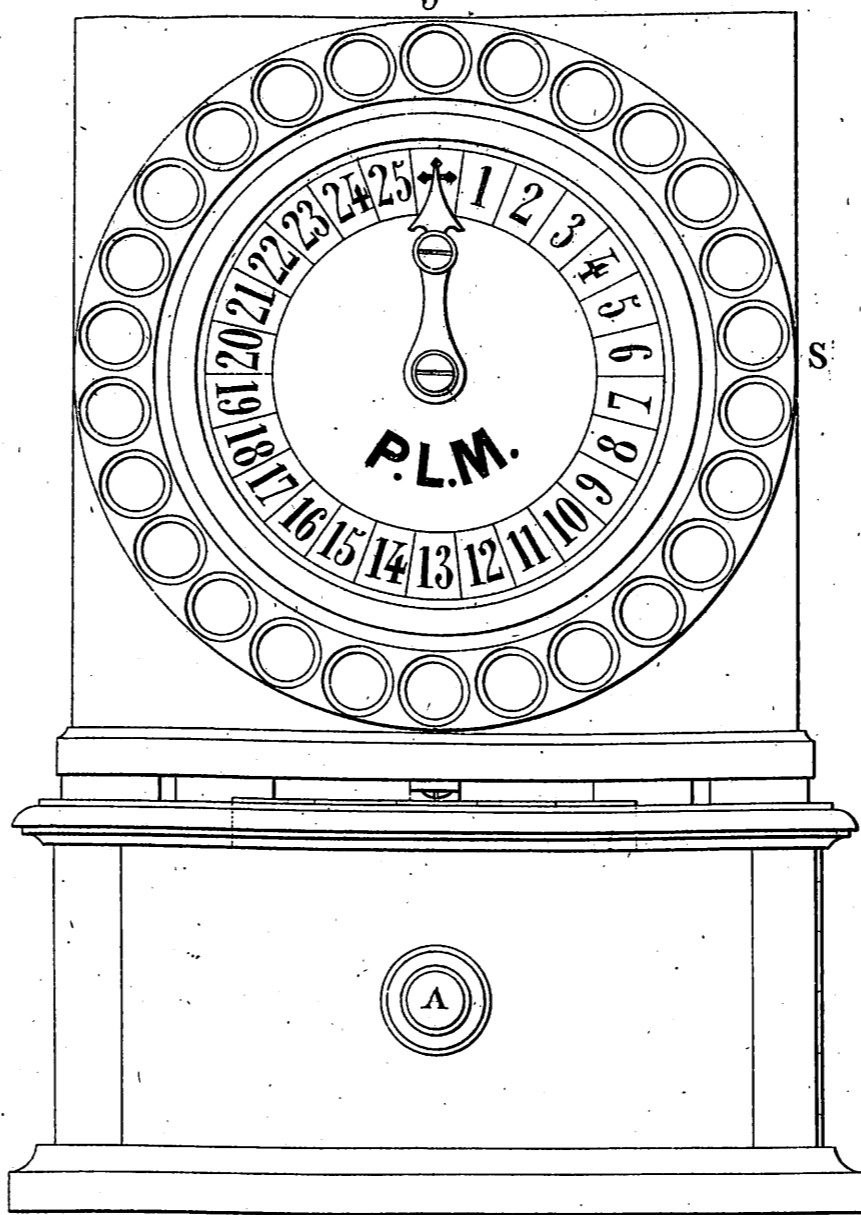
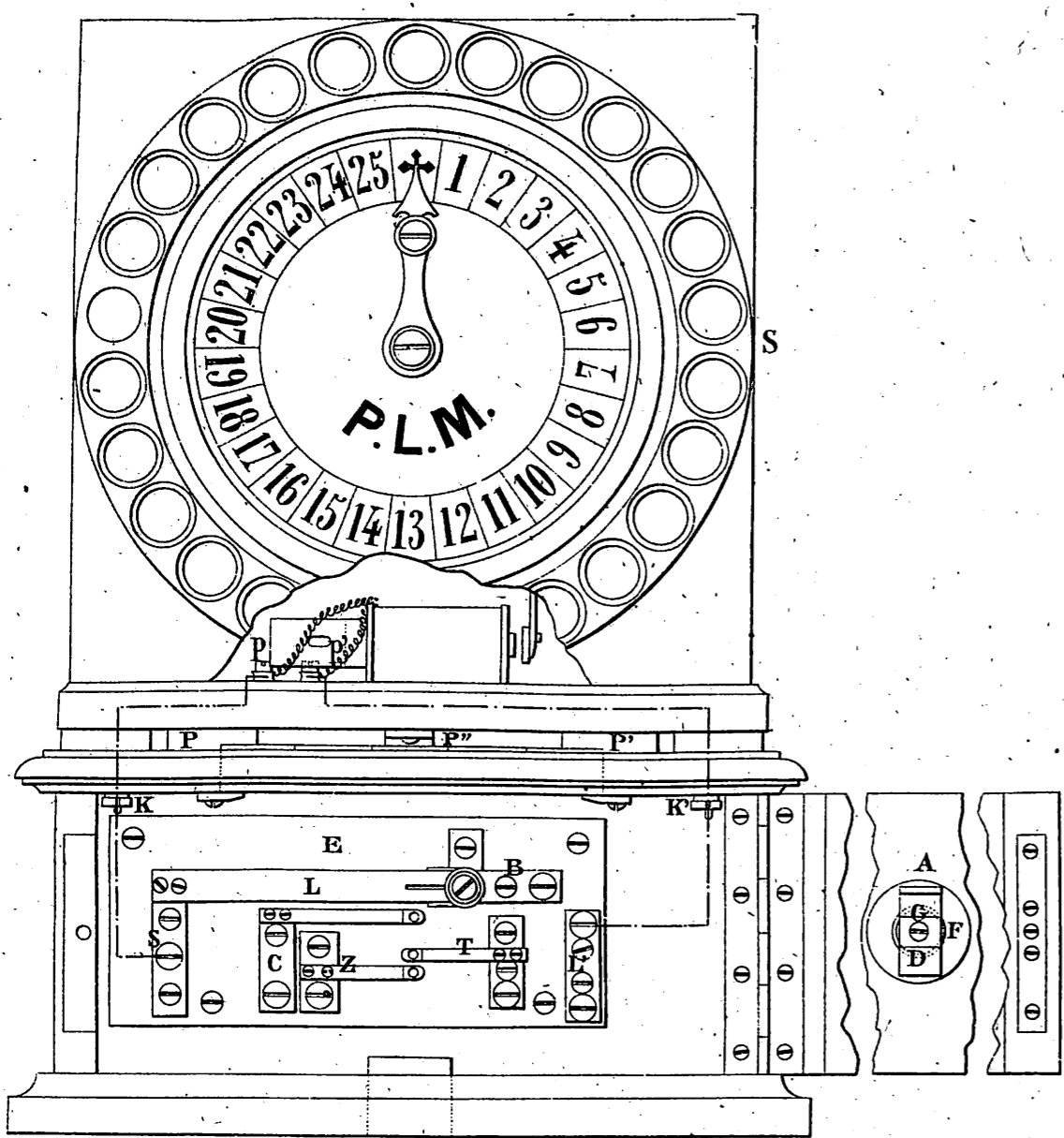
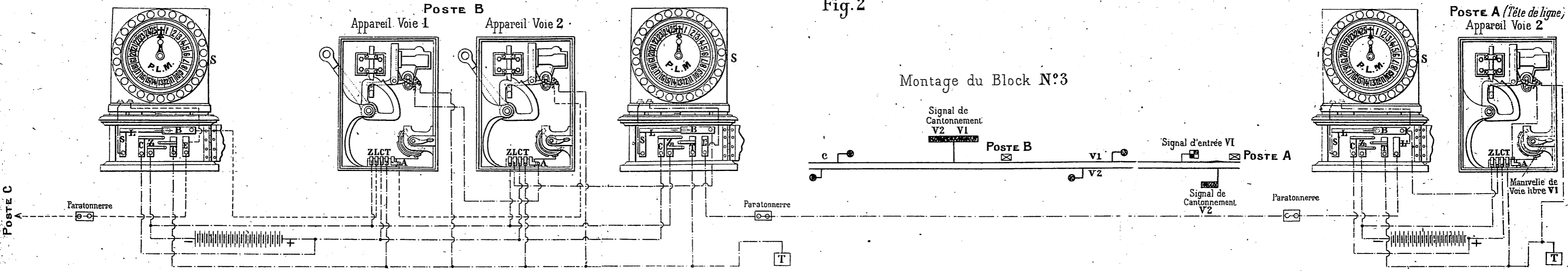

Fig. 2

Montage du Block N°3



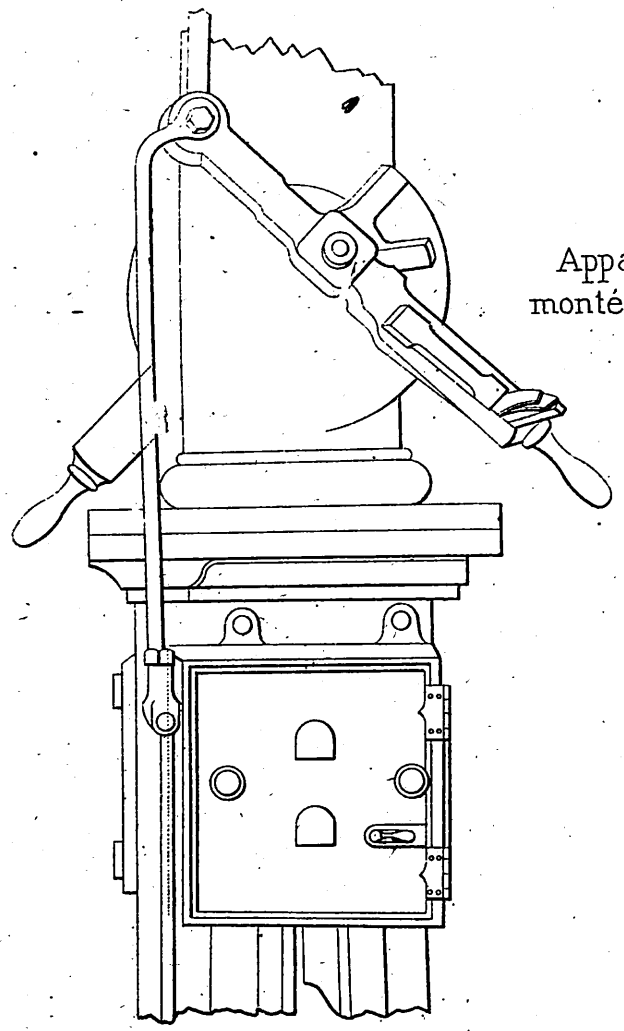

Fig. 1.
Appareil de Block N° 3
monté sur le soubassement
d'un sémaphore

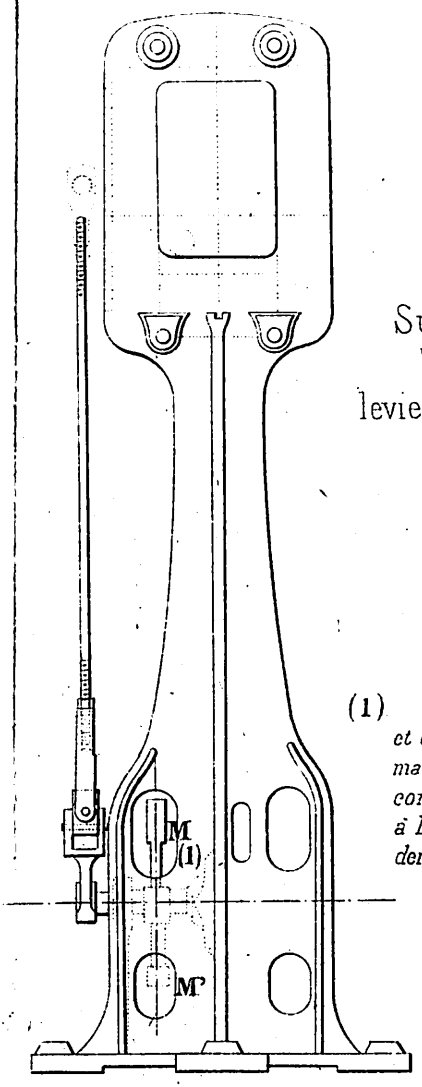

Fig. 2.
Support de Block N° 3 pour
Vignier horizontal ou
levier d'enclenchement économique

(1) Cette manivelle M est décalée de 180° et clavetée en M' lorsque le levier de manœuvre est rabattu dans la position correspondant au bras sémaphorique à l'arrêt ou lorsque le support est posé derrière le levier.

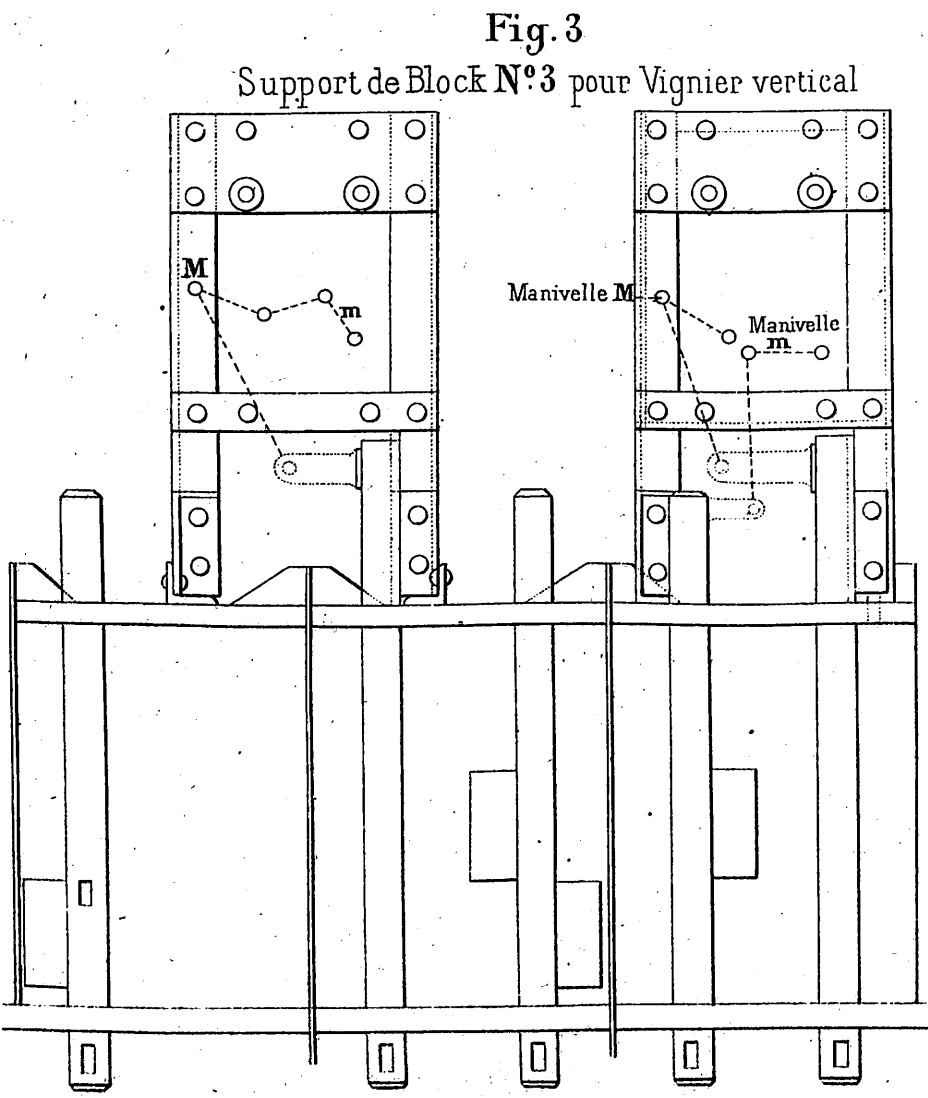
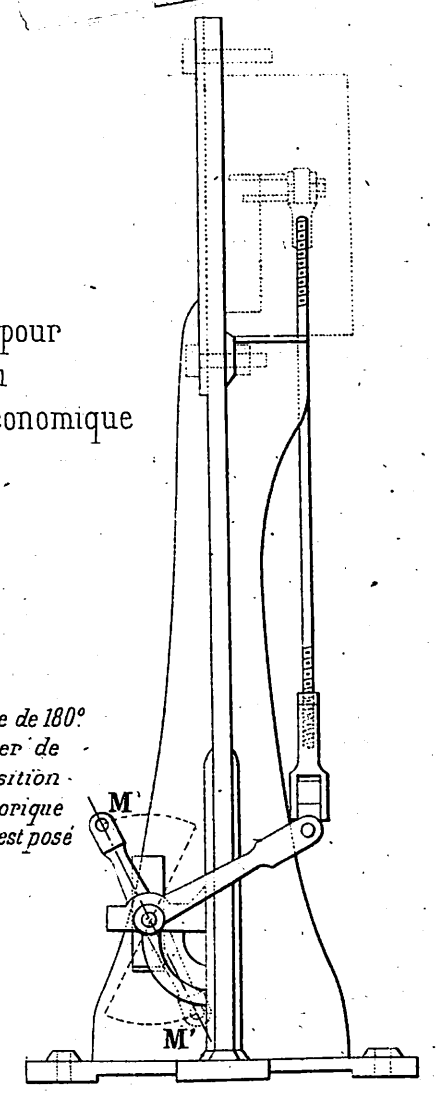

Fig. 3
Support de Block N° 3 pour Vignier vertical

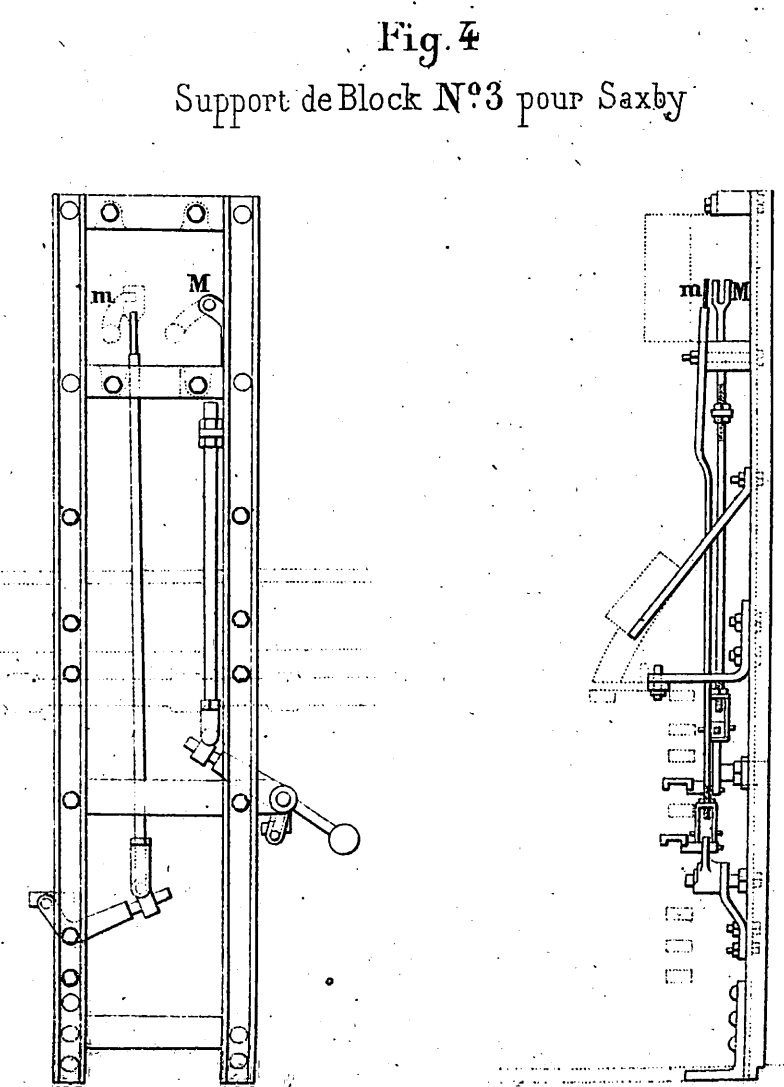
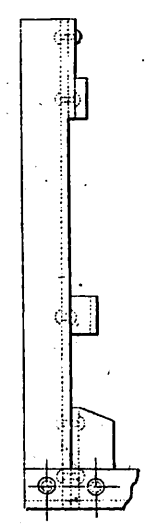

Fig. 4
Support de Block N° 3 pour Saxby

Fig. 1.

Bouton de Débloquage.

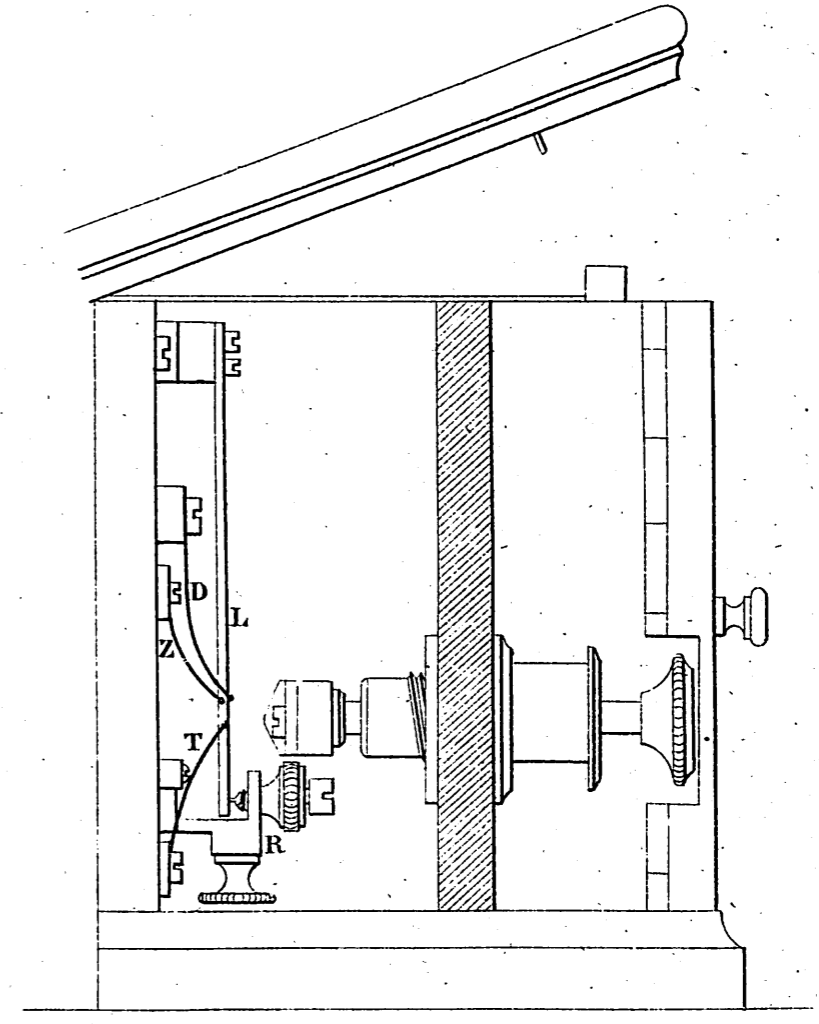
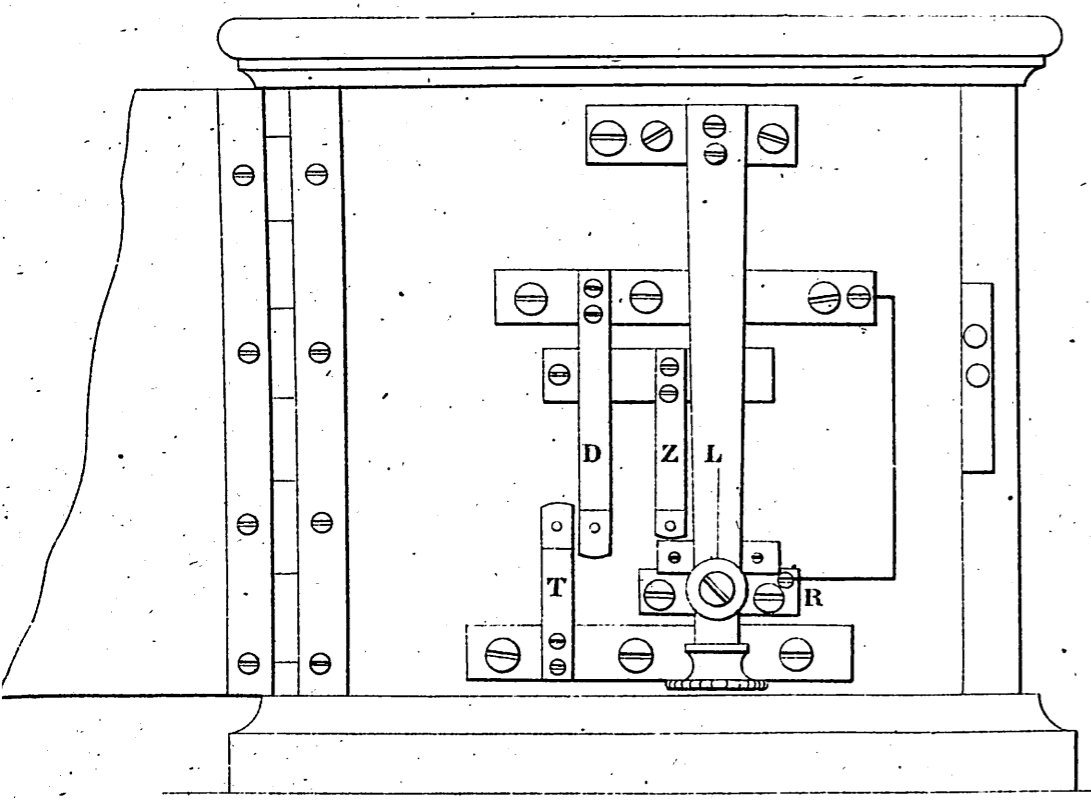

Fig. 2.
POSTE B.

